

# RETRACTABLE RANGEHOOD

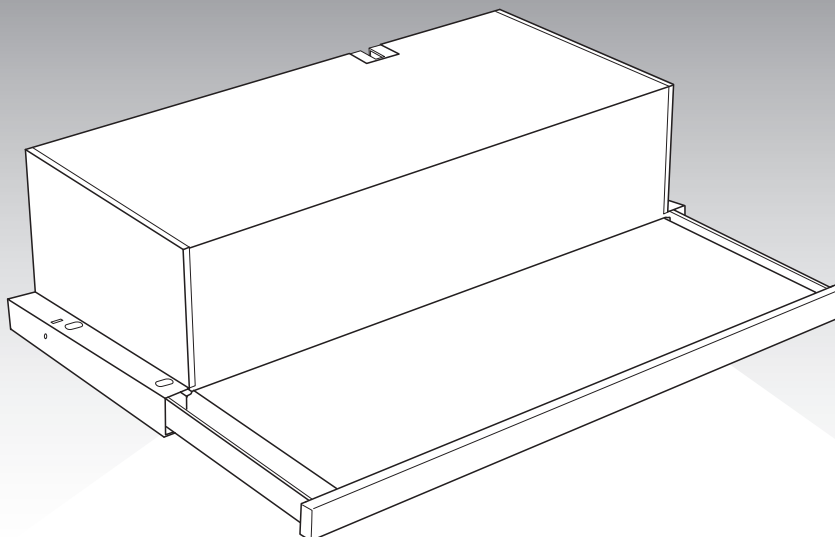

## OPERATION GUIDE INSTALLATION INSTRUCTIONS

Models: WRH605I • WRH608I • WRH908I • REHR6 • REHR9 • RRE634 • RRE635 • RRE934

These cooker hoods are domestic appliances which have been manufactured and tested to comply with Australian and New Zealand Standard AS/NZS 3350.2.31.

## **Safety Warnings**

- Young children should be supervised to ensure they do not play with the cooker hood.
- The cooker hood is not intended for use by young children or infirm persons without supervision.
- Ensure the cooker hood is switched off before carrying out maintenance, to avoid any possibility of electric shock.
- Grease filters must be removed every four weeks (maximum) for cleaning to reduce the risk of fire.
- Do not flambé under the cooker hood.
- This cooker hood is not recommended for barbeques.
- The exhaust air from the cooker hood must not be discharged into any heating flue, which may carry combustion products from other sources.
- Exhaust air must not be discharged into a wall cavity, unless the cavity is designed for the purpose.
- There must be adequate ventilation of the room when the cooker hood is used at the same time as appliances burning gas or other fuels.
- Always cover lit gas burners with pots or pans when the cooker hood is in use.
- Always switch off gas burners before you remove pots or pans.

## **Cleaning**

Wipe the cooker hood body and flue with a sponge or soft cloth soaked in warm soapy water. Do not use oven cleaners or other abrasive materials.

## **Electrical Connection**

- Check that the mains voltage matches with the voltage on the data plate inside the cooker hood.
- Check that the installation complies with standards of local gas and electricity authorities.
- If the supply cord is damaged, it must be replaced by the manufacturer or its service agent or a similarly qualified person in order to avoid a hazard.

## **Accessories**

- Use 125mm round exhaust ducting for best performance.
- When using flexible duct always install duct with the wire helix pulled taut to minimise pressure loss.
- Try to keep exhaust duct short and straight.
- Keep bends in the exhaust duct to a minimum.
- Do not reduce the size or restrict exhaust duct.

# INSTALLATION INSTRUCTIONS

Please read instructions carefully. Service calls resulting from incorrect installation will be charged for.

Exhaust air from the Rangehood must not be discharged into any heating flue which may carry combustion products from other sources. In addition, exhaust air must not be discharged into a wall cavity, unless the cavity is designed for the purpose. Adequate ventilation of the room must be ensured when the Rangehood is operating simultaneously with appliances burning gas or other fuels. Installation must comply in all respects with your gas and electrical authorities. This Rangehood is an indoor domestic appliance, and has been manufactured and tested to comply with Australian and New Zealand Standard AS/NZS 3350.2.31

It is recommended that the unit be positioned as close as possible to 600mm (electric hobs), 650mm (gas hobs), and no further from the hob than 800mm. The unit becomes less effective as the distance from the cooking surface to the hood increases.

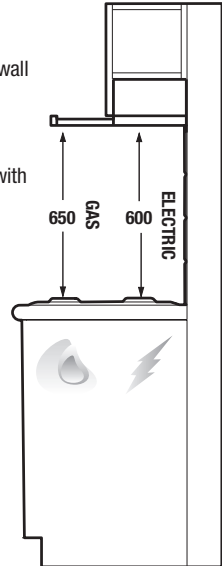

## FIXING POINT DIMENSIONS - 600mm Retractable cooker hood

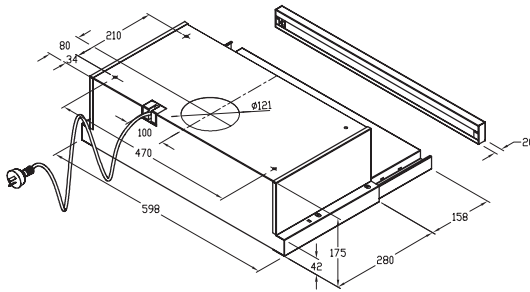

## FIXING POINT DIMENSIONS - 900mm Retractable cooker hood

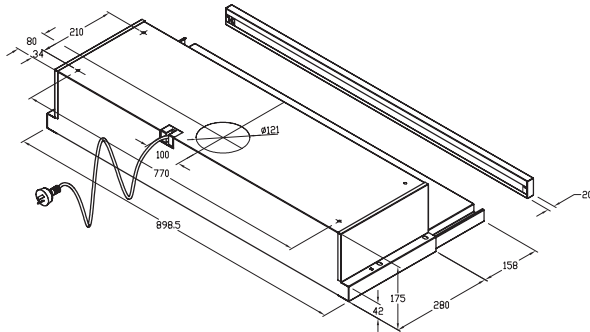

### DUCTING INSTALLATION

When installing with ducting pipe the Duct spigot must be fitted to the ducting hole on top of the body of the cooker hood

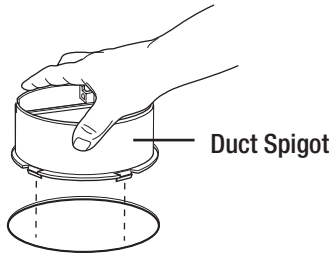

### RECIRCULATING INSTALLATION

(For Models: WRH608, RRE634, RRE635, WRH908 & RRE934)

When installed in recirculating mode the ducting hole cover **must** be fitted

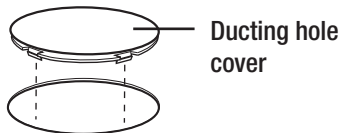

# INSTALLATION INSTRUCTIONS

## STANDARD DUCTED INSTALLATION

Models: WRH605I • WRH608I • WRH908I • REHR6 • REHR9 • RRE634 • RRE635 • RRE934

## DUCTING ACCESSORIES

For best performance 125mm ducting is recommended.

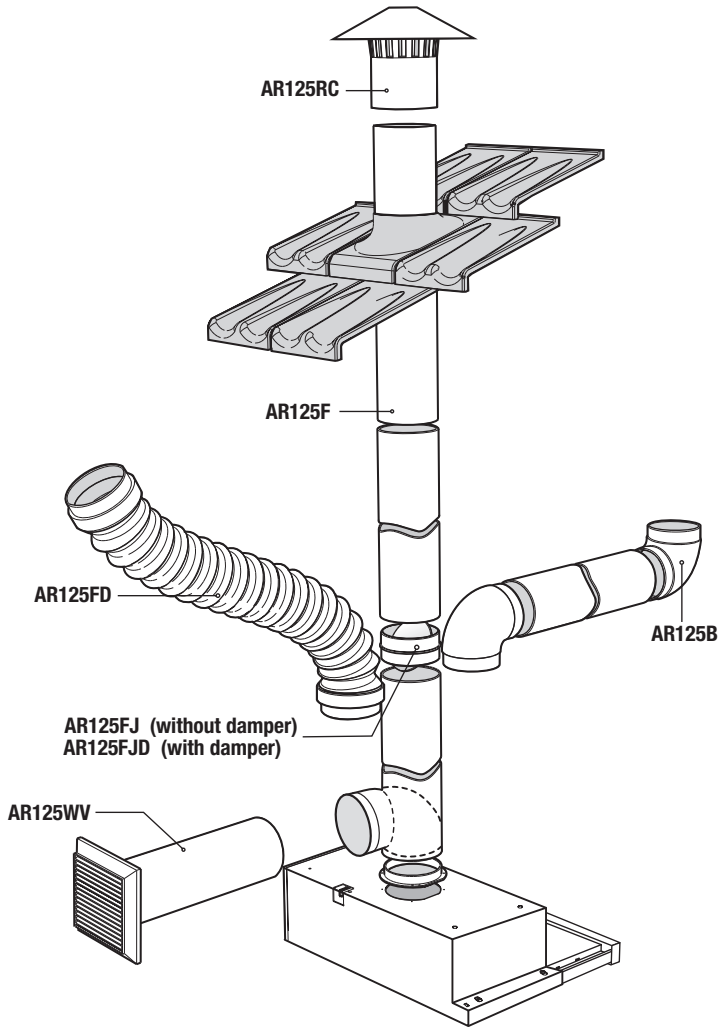

**ACCESSORIES CAN ONLY BE BOUGHT THROUGH THE SALES DEPARTMENT.  
THESE PARTS ARE NOT AVAILABLE THROUGH SPARE PARTS.**

# INSTALLATION INSTRUCTIONS

## INSTALLATION USING THE SUPPLIED DRAWER FASCIA

FOR MODELS: WRH605\* WRH608\* WRH908\* REHR6\* REHR9\* RRE634\* RRE934\*

Standard ducted installation calls for a door extension of 130mm whether the client opts to use the supplied draw fascia or a custom fascia of the same dimensions as that supplied.

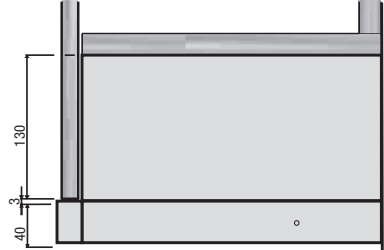

## RECIRCULATING VENT INSTALLATION

FOR MODELS: WRH608\* WRH908\* RRE634\* RRE934\* RRE635\*\* (already fitted with 70mm front panel)

**Note:** If the Rangehood is to be vented using the recirculating vent rather than standard ducting, the supplied drawer fascia is not to be used and must be replaced with a client specific custom fascia\*\*.

The custom drawer fascia must be a minimum of 70mm deep as air expelled through the recirculating vent must be deflected upwards.

The custom drawer fascia must be a minimum of 70mm deep as air expelled through the recirculating vent must be deflected upwards.

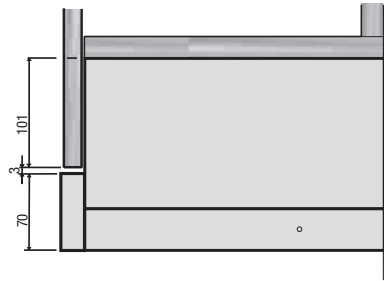

### Setting of circulation air door - single fan models

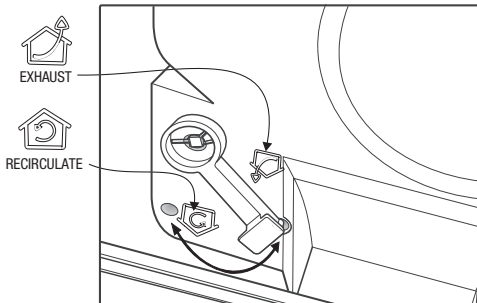

### Setting of circulation air doors - dual fan models

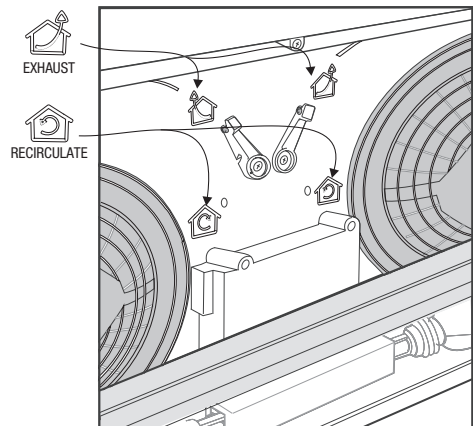

# INSTALLATION INSTRUCTIONS

## DUCTED RECIRCULATING INSTALLATION

FOR MODELS: REHR6\* REHR9\* WRH605I\*

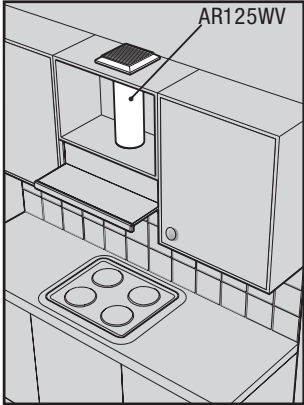

## ALL MODELS OPTIONAL CARBON FILTER

An optional carbon filter will diminish cooking odours in the recirculated air.

Depending on the frequency of use and the type of cooking, the expected life of carbon filters is from 1 to 6 months.

Replacement is required.

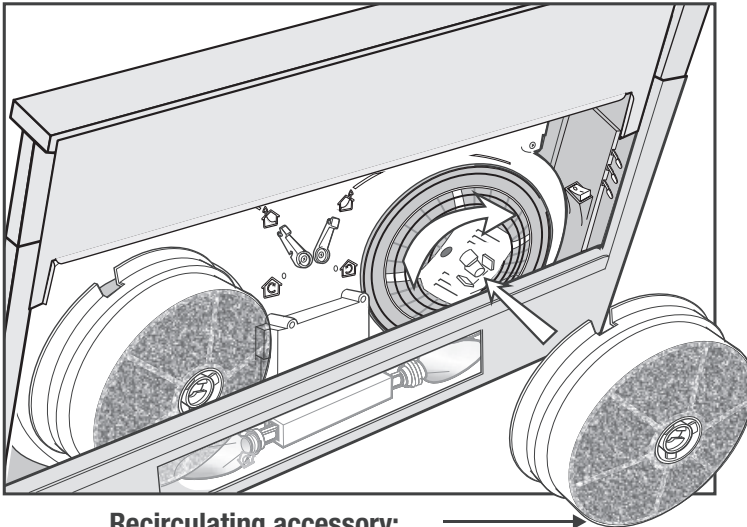

### **Recirculating accessory:**

Optional carbon filter ARCFD for recirculating mode only.

# OPERATION & MAINTENANCE

## OPERATION

MODELS: WRH605I\* REHR6\* REHR9\*

The operation of the light and the two-speed fan are controlled by the drawer action. (see diagram)

MODELS: WRH608I\* WRH908I\* RRE634\* RRE635\* RRE934\*

The operation of the lights and the three speed fans are controlled by the drawer action. (see diagram)

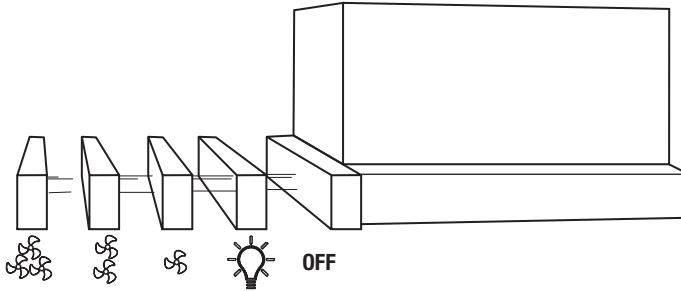

## TO REPLACE LIGHT GLOBES

1. Open drawer and remove filter.
2. Turn mains switch off before removing lamp.

Replace with 40W maximum E14 candle lamp. Depending on model will require 1 or 2 globes.

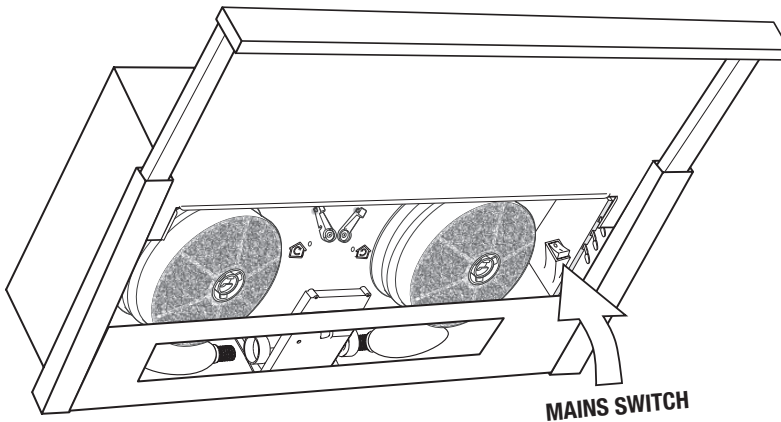

# OPERATION & MAINTENANCE

## MAINTENANCE

To maintain efficiency and reduce fire risk, filters should be removed every four weeks (maximum) for cleaning. Soak and agitate filters in hot soapy water or washing soda. Rinse, drain, shake well and replace.

Do not use caustic solutions or other corrosive agents.

The filters can be washed in the dishwasher, but could dis-colour caused by dishwasher cleaning agents. It is recommended the filters be placed on the top shelf of the dishwasher.

**NOTE:** Where fitted, optional carbon filters are intended to be a disposable item and should be discarded when saturated. Washing the carbon filter is not recommended.

## REMOVE FILTERS FOR CLEANING

1. Slide filter tray forward 1cm.
2. Push in clip on either side to release filter. Fig 1.
3. Pull filter downwards to remove. Repeat 2 & 3 for models with a second filter. Fig 2.
4. Turn off mains switch before cleaning drawer and cooker hood body.
5. After cleaning, re-fit filters making sure the clip pins are securely fitted into the locating holes in the cookerhood body and for twin filter versions, also located in the pull out drawer section.
6. Holding clip in, push opposite side of filter up until pins are over locating holes.
7. Release clip ensuring filter is securely fitted.

**Safety Tips:** Use of two hands for removal and re-fitting of filters is recommended to avoid accidental dropping of filters which could cause damage to your cooktop or kitchen surfaces.

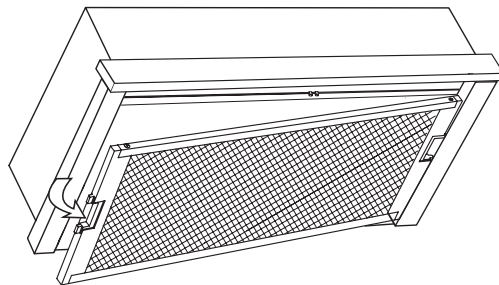
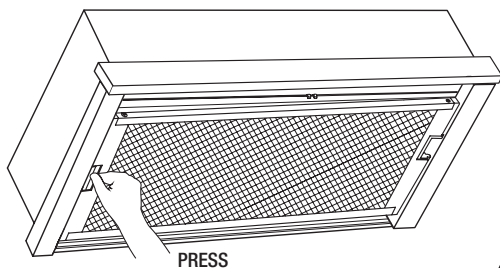

Should you require further instructions in the use and care of your cooker hood please contact the Customer Care Centre on 1300 363 640 (Australia, Mon-Fri 8.00am-5.00pm Eastern Standard time) or +649 573 2384 (New Zealand, Mon-Fri 8.00am-5.00pm). If you have a warranty or spare parts enquiry, you should call the number listed on the warranty page.



# WARRANTY

## **Electrolux warranty**

FOR SALES IN AUSTRALIA AND NEW ZEALAND  
APPLIANCE: RANGEHOOD

**This document sets out the terms and conditions of product warranties for Electrolux branded appliances. It is an important document. Please keep it with your proof of purchase documents in a safe place for future reference should you require service for your Electrolux appliance**

### General Terms and Conditions

1. In this warranty
  - (a) 'Electrolux' means Electrolux Home Products Pty Ltd ABN 51 004 762 341 in respect of Appliances purchased in Australia and Electrolux (NZ) Limited in respect of Appliances purchased in New Zealand;
  - (b) 'Appliance' means any Electrolux product purchased by you accompanied by this document;
  - (c) 'Warranty Period' means
    - (i) where you use the Appliance for personal, domestic or household purposes in Australia the period of 24 months and in New Zealand the period of 24 months;
    - (ii) where you use the Appliance for commercial purposes, in Australia the period of 12 months and in New Zealand the period of 12 months, (if the period stated is 0 months you are not covered by this product warranty) following the date of original purchase of the Appliance;
  - (d) 'you' means the purchaser of the Appliance not having purchased the appliance for re-sale, and 'your' has a corresponding meaning.
2. This warranty only applies to Appliances purchased and used in Australia or New Zealand and is in addition to (and does not exclude, restrict, or modify in any way) any non-excludable statutory warranties in Australia or New Zealand.
3. Electrolux warrants that, when dispatched from an Electrolux warehouse, the Appliance is free from defects in materials and workmanship for the Warranty Period.
4. During the Warranty Period Electrolux or its Authorised Service Centre will, at no extra charge if your appliance is readily accessible without special equipment, and subject to these terms and conditions, repair or replace any parts which it considers to be defective. You agree that any replaced Appliances or parts become the property of Electrolux. This warranty does not apply to light globes, batteries, filters or similar perishable parts.
5. Parts and Appliances not supplied by Electrolux are not covered by this warranty.
6. Where you are within an Electrolux service area, this warranty covers the cost of transport of the Appliance to and from Authorised Service Centres of Electrolux and travelling costs for representatives of the Authorised Service Centre to and from your home or business. If you are outside an Electrolux service area, you will bear these costs. For information about whether you are within an Electrolux service area, please phone 13 13 49 in Australia, or 0800 10 66 10 in New Zealand.
7. Proof of purchase is required before you can make a claim under this warranty.

8. You may not make a claim under this warranty unless the defect claimed is due to faulty or defective parts or workmanship. Electrolux is not liable in the following situations (which are not exhaustive):
  - (a) The Appliance is damaged by:
    - (i) accident
    - (ii) misuse or abuse, including failure to properly maintain or service
    - (iii) normal wear and tear
    - (iv) power surges, electrical storm damage or incorrect power supply
    - (v) incomplete or improper installation
    - (vi) incorrect, improper or inappropriate operation
    - (vii) insect or vermin infestation.
  - (b) The Appliance is modified without authority from Electrolux in writing.
  - (c) The Appliance's serial number or warranty seal has been removed or defaced.
  - (d) The Appliance was serviced or repaired by anyone other than Electrolux or its Authorised Service Centres.
9. This warranty, the contract to which it relates and the relationship between you and Electrolux are governed by the law applicable in the Australian State where the Appliance was purchased or the law applicable in New Zealand if the Appliance was purchased in New Zealand. Where the Appliance was purchased in New Zealand for business purposes the Consumer Guarantee Act does not apply.

### Limitation of Liability

10. To the extent permitted by law:
  - (a) Electrolux excludes all warranties other than as contained in this document;
  - (b) Electrolux shall not be liable for any loss or damage whether direct or indirect or consequential arising from your purchase, use or non-use of the Appliance.
11. Provisions of the Trade Practices Act and State consumer legislation in Australia, and the Consumer Guarantees Act, the Sale of Goods Act and the Fair Trading Act in New Zealand, imply warranties or conditions, or impose obligations, upon Electrolux which cannot be excluded, restricted or modified. To the extent permitted by law, the liability of Electrolux (if any) arising out of or in relation to the Appliance or any services supplied by Electrolux shall be limited (where it is fair and reasonable to do so):
  - (a) in the case of Appliances, at its option, to the replacement or repair of the Appliances or the supply of equivalent products or the payment of the cost of replacing the Appliances or having the Appliances repaired or of acquiring equivalent Appliances. Upon being replaced, parts and Appliances become the property of Electrolux; or
  - (b) in the case of services, at its option, to the supply of the services again or the payment of the cost of having the services re-supplied; and in the case of Appliances or services supplied in New Zealand, loss or damage whether direct or indirect or consequential that is reasonably foreseeable.

### Privacy

You acknowledge that in the event that you make a warranty claim it will be necessary for Electrolux and its Authorised Service Centres to exchange information in relation to you to enable Electrolux to meet its obligations under this warranty.

### Important Notice

Before Calling a Service Technician please check carefully the operating instructions, service booklet and the warranty terms and conditions.

<p><b>FOR SERVICE</b> OR TO FIND THE ADDRESS OF YOUR NEAREST STATE SERVICE CENTRE IN AUSTRALIA <b>Please call 13 13 49</b> For the cost of a local call (Australia only)</p>	<p>SERVICE AUSTRALIA  <b>Electrolux</b> ELECTROLUX HOME PRODUCTS</p>	<p><b>FOR SPARE PARTS</b> OR TO FIND THE ADDRESS OF YOUR NEAREST STATE SPARE PARTS CENTRE IN AUSTRALIA <b>Please call 13 13 50</b> For the cost of a local call (Australia only)</p>
--	---	--

<p><b>FOR SERVICE</b> OR TO FIND THE ADDRESS OF YOUR NEAREST AUTHORISED SERVICE CENTRE IN NEW ZEALAND <b>Free call 0800 10 66 10</b> (New Zealand only)</p>	<p><b>NEW ZEALAND SPARE PARTS CENTRES</b> <b>AUCKLAND</b> Prime Distributors Ltd. 8 Highbrook Drive, East Tamaki ..... (09) 273 3580 <b>CHRISTCHURCH</b> Prime Distributors Ltd. Unit 1, 127 Montreal Street ... (03) 377 1009 R. Redpath Ltd. 55 Ferry Road ..... (03) 379 0446 <b>DUNEDIN</b> South City Champion, 590 Hillside Road ..... (03) 455 5443</p> <p> <b>Electrolux</b> ELECTROLUX HOME PRODUCTS</p>
---	--





**ATTENTION INSTALLER:**  
PLEASE LEAVE THIS BOOKLET WITH THE RANGEHOOD OWNER.  
THANK YOU.

 **The Electrolux Group.** *The world's No.1 choice.*  
KITCHEN, CLEANING AND OUTDOOR APPLIANCES

Issue 01.  
15/11/05